

PROPRIETARY AND CONFIDENTIAL

THE INFORMATION CONTAINED IN THIS DRAWING IS THE SOLE PROPERTY OF TRAKLOC. ANY REPRODUCTION IN PART OR AS A WHOLE WITHOUT THE WRITTEN PERMISSION OF TRAKLOC IS PROHIBITED.

ITEM NO.	PART NO.
1	TTS TRAK
2	TSO STUD
3	TSE SLIP EXT
4	Bridge Channel
5	Bridge Channel Brace

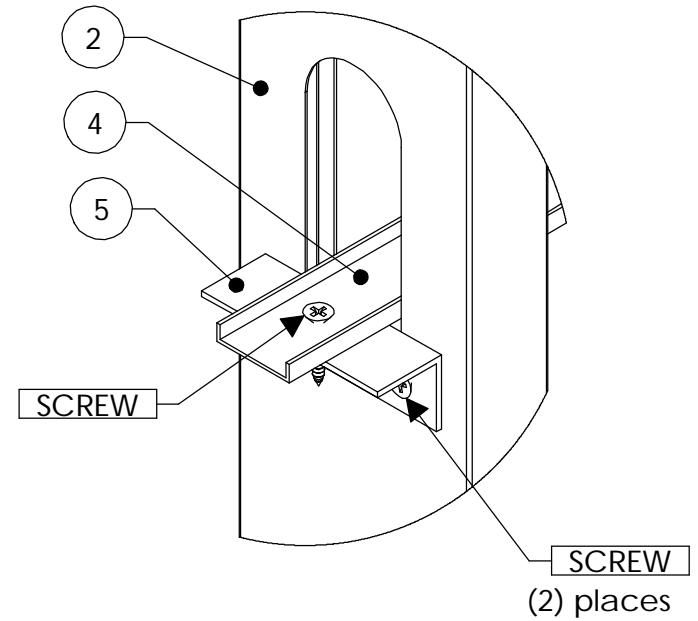
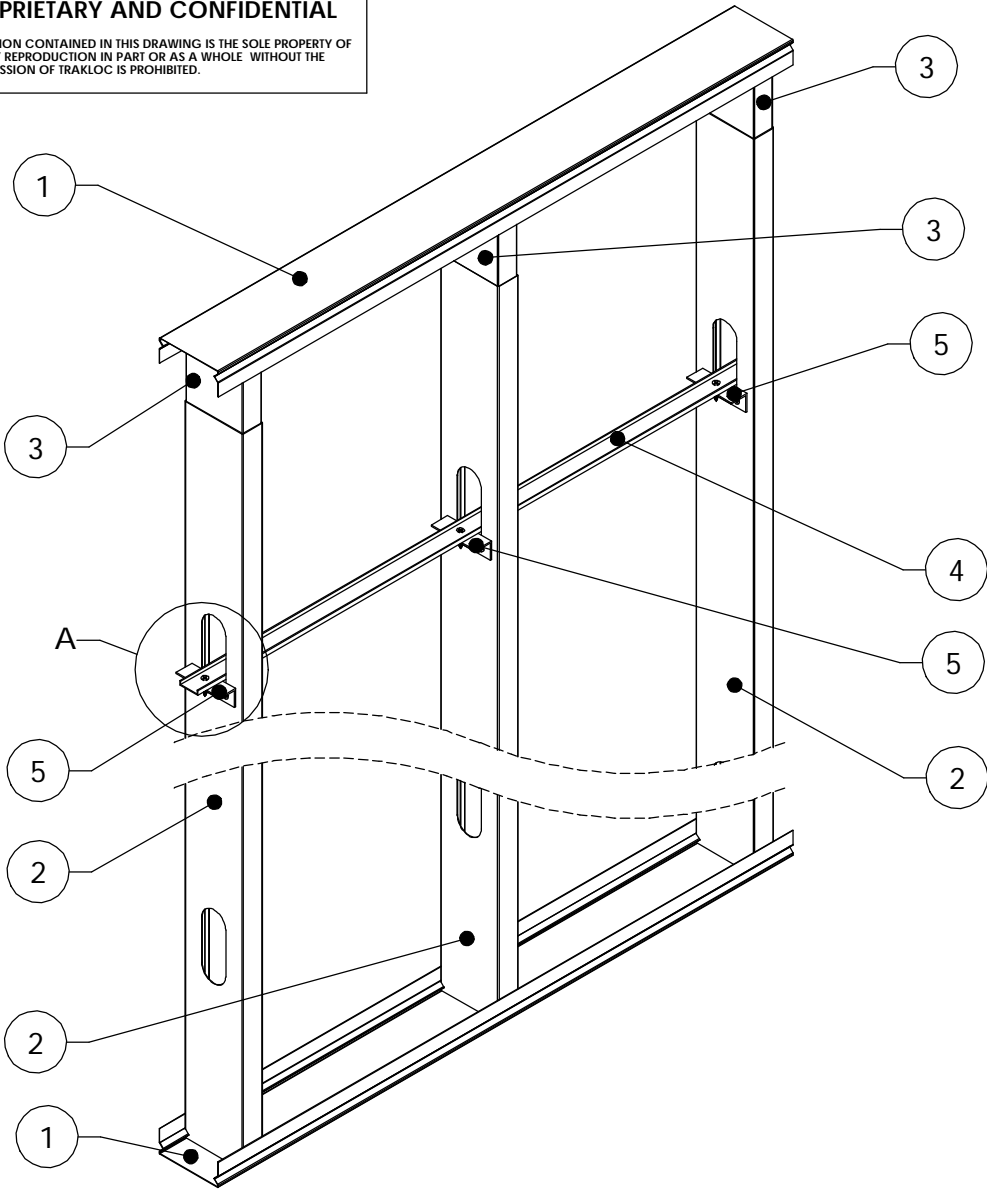

DETAIL A
SCALE 1 : 1

**Bridging Channel with
Clip Angle**

TITLE: BRIDGING CHANNEL WITH CLIP ANGLE ASSEMBLY

TRAKLOC QUANTITY: 1

UNLESS OTHERWISE SPECIFIED:		DATE	NAME
TOLERANCES: DIMENSIONS: INCHES		2/15/2005	JLB
LINEAR: .0005		CHECKED	2/15/2005
ANGLE: 1 DEG		ENG APPR	2/15/2005
OTHERS: CHAMFER ALL EDGES .04-.05		MFG APPR	2/15/2005
X .0005		Q.A.	2/15/2005
X.X .0010			
X.XX .0020			
X.XXX .0050			
X.XXXX .0100			
X.XXXXX .0150			
X.XXXXXX .0200			
X.XXXXXXX .0300			
X.XXXXXXX .0400			
X.XXXXXXX .0500			
X.XXXXXXX .0600			
X.XXXXXXX .0700			
X.XXXXXXX .0800			
X.XXXXXXX .0900			
X.XXXXXXX .1000			
X.XXXXXXX .1200			
X.XXXXXXX .1500			
X.XXXXXXX .2000			
X.XXXXXXX .2500			
X.XXXXXXX .3000			
X.XXXXXXX .3750			
X.XXXXXXX .4500			
X.XXXXXXX .5000			
X.XXXXXXX .6250			
X.XXXXXXX .7500			
X.XXXXXXX .8750			
X.XXXXXXX 1.0000			
X.XXXXXXX 1.2500			
X.XXXXXXX 1.5000			
X.XXXXXXX 1.7500			
X.XXXXXXX 2.0000			
X.XXXXXXX 2.5000			
X.XXXXXXX 3.0000			
X.XXXXXXX 3.7500			
X.XXXXXXX 4.5000			
X.XXXXXXX 5.0000			
X.XXXXXXX 6.0000			
X.XXXXXXX 7.0000			
X.XXXXXXX 8.0000			
X.XXXXXXX 9.0000			
X.XXXXXXX 10.0000			
X.XXXXXXX 12.0000			
X.XXXXXXX 15.0000			
X.XXXXXXX 20.0000			
X.XXXXXXX 25.0000			
X.XXXXXXX 30.0000			
X.XXXXXXX 37.5000			
X.XXXXXXX 45.0000			
X.XXXXXXX 50.0000			
X.XXXXXXX 60.0000			
X.XXXXXXX 75.0000			
X.XXXXXXX 90.0000			
X.XXXXXXX 100.0000			
X.XXXXXXX 125.0000			
X.XXXXXXX 150.0000			
X.XXXXXXX 175.0000			
X.XXXXXXX 200.0000			
X.XXXXXXX 250.0000			
X.XXXXXXX 300.0000			
X.XXXXXXX 375.0000			
X.XXXXXXX 450.0000			
X.XXXXXXX 500.0000			
X.XXXXXXX 600.0000			
X.XXXXXXX 750.0000			
X.XXXXXXX 900.0000			
X.XXXXXXX 1000.0000			
X.XXXXXXX 1250.0000			
X.XXXXXXX 1500.0000			
X.XXXXXXX 1750.0000			
X.XXXXXXX 2000.0000			
X.XXXXXXX 2500.0000			
X.XXXXXXX 3000.0000			
X.XXXXXXX 3750.0000			
X.XXXXXXX 4500.0000			
X.XXXXXXX 5000.0000			
X.XXXXXXX 6000.0000			
X.XXXXXXX 7500.0000			
X.XXXXXXX 9000.0000			
X.XXXXXXX 10000.0000			
X.XXXXXXX 12500.0000			
X.XXXXXXX 15000.0000			
X.XXXXXXX 17500.0000			
X.XXXXXXX 20000.0000			
X.XXXXXXX 25000.0000			
X.XXXXXXX 30000.0000			
X.XXXXXXX 37500.0000			
X.XXXXXXX 45000.0000			
X.XXXXXXX 50000.0000			
X.XXXXXXX 60000.0000			
X.XXXXXXX 75000.0000			
X.XXXXXXX 90000.0000			
X.XXXXXXX 100000.0000			
X.XXXXXXX 125000.0000			
X.XXXXXXX 150000.0000			
X.XXXXXXX 175000.0000			
X.XXXXXXX 200000.0000			
X.XXXXXXX 250000.0000			
X.XXXXXXX 300000.0000			
X.XXXXXXX 375000.0000			
X.XXXXXXX 450000.0000			
X.XXXXXXX 500000.0000			
X.XXXXXXX 600000.0000			
X.XXXXXXX 750000.0000			
X.XXXXXXX 900000.0000			
X.XXXXXXX 1000000.0000			
X.XXXXXXX 1250000.0000			
X.XXXXXXX 1500000.0000			
X.XXXXXXX 1750000.0000			
X.XXXXXXX 2000000.0000			
X.XXXXXXX 2500000.0000			
X.XXXXXXX 3000000.0000			
X.XXXXXXX 3750000.0000			
X.XXXXXXX 4500000.0000			
X.XXXXXXX 5000000.0000			
X.XXXXXXX 6000000.0000			
X.XXXXXXX 7500000.0000			
X.XXXXXXX 9000000.0000			
X.XXXXXXX 10000000.0000			
X.XXXXXXX 12500000.0000			
X.XXXXXXX 15000000.0000			
X.XXXXXXX 17500000.0000			
X.XXXXXXX 20000000.0000			
X.XXXXXXX 25000000.0000			
X.XXXXXXX 30000000.0000			
X.XXXXXXX 37500000.0000			
X.XXXXXXX 45000000.0000			
X.XXXXXXX 50000000.0000			
X.XXXXXXX 60000000.0000			
X.XXXXXXX 75000000.0000			
X.XXXXXXX 90000000.0000			
X.XXXXXXX 100000000.0000			
X.XXXXXXX 125000000.0000			
X.XXXXXXX 150000000.0000			
X.XXXXXXX 175000000.0000			
X.XXXXXXX 200000000.0000			
X.XXXXXXX 250000000.0000			
X.XXXXXXX 300000000.0000			
X.XXXXXXX 375000000.0000			
X.XXXXXXX 450000000.0000			
X.XXXXXXX 500000000.0000			
X.XXXXXXX 600000000.0000			
X.XXXXXXX 750000000.0000			
X.XXXXXXX 900000000.0000			
X.XXXXXXX 1000000000.0000			
X.XXXXXXX 1250000000.0000			
X.XXXXXXX 1500000000.0000			
X.XXXXXXX 1750000000.0000			
X.XXXXXXX 2000000000.0000			
X.XXXXXXX 2500000000.0000			
X.XXXXXXX 3000000000.0000			
X.XXXXXXX 3750000000.0000			
X.XXXXXXX 4500000000.0000			
X.XXXXXXX 5000000000.0000			
X.XXXXXXX 6000000000.0000			
X.XXXXXXX 7500000000.0000			
X.XXXXXXX 9000000000.0000			
X.XXXXXXX 10000000000.0000			
X.XXXXXXX 12500000000.0000			
X.XXXXXXX 15000000000.0000			
X.XXXXXXX 17500000000.0000			
X.XXXXXXX 20000000000.0000			
X.XXXXXXX 25000000000.0000			
X.XXXXXXX 30000000000.0000			
X.XXXXXXX 37500000000.0000			
X.XXXXXXX 45000000000.0000			
X.XXXXXXX 50000000000.0000			
X.XXXXXXX 60000000000.0000			
X.XXXXXXX 75000000000.0000			
X.XXXXXXX 90000000000.0000			
X.XXXXXXX 100000000000.0000			
X.XXXXXXX 125000000000.0000			
X.XXXXXXX 150000000000.0000			
X.XXXXXXX 175000000000.0000			
X.XXXXXXX 200000000000.0000			
X.XXXXXXX 250000000000.0000			
X.XXXXXXX 300000000000.0000			
X.XXXXXXX 375000000000.0000			
X.XXXXXXX 450000000000.0000			
X.XXXXXXX 500000000000.0000			
X.XXXXXXX 600000000000.0000			
X.XXXXXXX 750000000000.0000			
X.XXXXXXX 900000000000.0000			
X.XXXXXXX 1000000000000.0000			
X.XXXXXXX 1250000000000.0000			
X.XXXXXXX 1500000000000.0000			
X.XXXXXXX 1750000000000.0000			
X.XXXXXXX 2000000000000.0000			
X.XXXXXXX 2500000000000.0000			
X.XXXXXXX 3000000000000.0000			
X.XXXXXXX 3750000000000.0000			
X.XXXXXXX 4500000000000.0000			
X.XXXXXXX 5000000000000.0000			
X.XXXXXXX 6000000000000.0000			
X.XXXXXXX 7500000000000.0000			
X.XXXXXXX 9000000000000.0000			
X.XXXXXXX 10000000000000.0000			
X.XXXXXXX 12500000000000.0000			
X.XXXXXXX 15000000000000.0000			
X.XXXXXXX 17500000000000.0000			
X.XXXXXXX 20000000000000.0000			
X.XXXXXXX 25000000000000.0000			
X.XXXXXXX 30000000000000.0000			
X.XXXXXXX 37500000000000.0000			
X.XXXXXXX 45000000000000.0000			
X.XXXXXXX 50000000000000.0000			
X.XXXXXXX 60000000000000.0000			
X.XXXXXXX 75000000000000.0000			
X.XXXXXXX 90000000000000.0000			
X.XXXXXXX 100000000000000.0000			
X.XXXXXXX 125000000000000.0000			
X.XXXXXXX 150000000000000.0000			
X.XXXXXXX 175000000000000.0000			
X.XXXXXXX 200000000000000.0000			
X.XXXXXXX 250000000000000.0000			
X.XXXXXXX 300000000000000.0000			
X.XXXXXXX 375000000000000.0000			
X.XXXXXXX 450000000000000.0000			
X.XXXXXXX 500000000000000.0000			
X.XXXXXXX 600000000000000.0000			
X.XXXXXXX 750000000000000.0000			
X.XXXXXXX 900000000000000.0000			
X.XXXXXXX 1000000000000000.0000			
X.XXXXXXX 1250000000000000.0000			
X.XXXXXXX 1500000000000000.0000			
X.XXXXXXX 1750000000000000.0000			
X.XXXXXXX 2000000000000000.0000			
X.XXXXXXX 2500000000000000.0000			
X.XXXXXXX 3000000000000000.0000			
X.XXXXXXX 3750000000000000.0000			
X.XXXXXXX 4500000000000000.0000			
X.XXXXXXX 5000000000000000.0000			
X.XXXXXXX 6000000000000000.0000			
X.XXXXXXX 7500000000000000.0000			
X.XXXXXXX 9000000000000000.0000			
X.XXXXXXX 10000000000000000.0000			
X.XXXXXXX 12500000000000000.0000			
X.XXXXXXX 15000000000000000.0000			
X.XXXXXXX 17500000000000000.0000			
X.XXXXXXX 20000000000000000.0000			
X.XXXXXXX 25000000000000000.0000			
X.XXXXXXX 30000000000000000.0000			
X.XXXXXXX 37500000000000000.0000			
X.XXXXXXX 45000000000000000.0000			
X.XXXXXXX 50000000000000000.0000			
X.XXXXXXX 60000000000000000.0000			
X.XXXXXXX 75000000000000000.0000			
X.XXXXXXX 90000000000000000.0000			
X.XXXXXXX 100000000000000000.0000			
X.XXXXXXX 125000000000000000.0000			
X.XXXXXXX 150000000000000000.0000			
X.XXXXXXX 175000000000000000.0000			
X.XXXXXXX 200000000000000000.0000			
X.XXXXXXX 250000000000000000.0000			
X.XXXXXXX 300000000000000000.0000			
X.XXXXXXX 375000000000000000.0000			
X.XXXXXXX 450000000000000000.0000			
X.XXXXXXX 500000000000000000.0000			